

Avionics

IFR 6015 Ramp Test Set



AEROFLEX
A passion for performance.

The IFR 6015 is a compact, lightweight and weatherproof unit designed for testing transponder modes 1,2,3A/C/S, TCAS I, II and Military E-TCAS as well as TACAN.

- One main user screen for each test mode
- Detachable antenna
- Large display
- Simple user interface
- Lightweight and compact <8 lbs. (3.6 kg)
- Battery 6 hours plus duration
- Fully FAR Part 43 Appendix F compliant
- European Elementary and Enhanced Surveillance
- TACAN and IFF Modes 1 & 2
- Emulates preset modes of TACAN Test Sets Generic DoD, AN/ASM-663, AN/ARM-184, Bradley 2650 & 2655



The IFR 6015 features an extremely easy to use interface where every parameter the user commonly needs to view is displayed on screen.

Controls

Dedicated Mode keys for XPDR, TACAN/DME and TCAS allow quick selection of the operational mode.

The application dependant softkeys and data select/slew keys provide an intuitive man-machine interface.

TACAN mode is provided with dedicated keys for frequency/channel selection and RF level control. For frequently varied parameters in TACAN and TCAS modes, such as Range and Rate, dedicated keys are provided.

Operational Modes

Each operational mode has one main user screen. The operational modes are:

XPDR (Sub-Modes: ADS-B MON, ADS-B GEN & GICB)

TACAN (Sub-Modes: T/R Norm, Inv, Range Only; A/A Beacon, Inv, Range Only)

TCAS 1, 2 (Sub-Mode: TIS)

E-TCAS

Most tests can be completed without leaving the main user screens. This simplifies the line technician's testing task.

For the very latest specifications visit www.aeroflex.com

```

XPDR-AUTO TEST      PASS      BAT 2.5 Hr

CONFIG:MK12/S-M4          LEVEL=4
ANTENNA:BOTTOM
REPLIES =1,2,3A,C,S      FREQ =1090.12 MHZ
TOP ERP =57.1 dBm        MTL =-74.0 dBm
BOT ERP =56.0 dBm        MTL =-73.1 dBm
3A CODE =1234            C ALT =35000 ft
1 CODE =1234            2 CODE =1234
TAIL =N12345            DF17 DETECTED=NO
FLT ID =AA-50           AA=AC3421(53032041)
FS=5-NO ALERT           SPI IN AIR
VS=IN AIR              COUNTRY=United States

RUN TEST    TEST LIST    CONFIG    SELECT ANT

```

(IFF System Information in Public Domain)

```

XPDR-3A/C SPAC/WDTH FAIL      BAT 2.5 Hr

F1 WIDTH ▶3A= 0.300 us        C= 0.450 us
F2 WIDTH 3A= 0.400 us        ▶C= 0.600 us
F1-F2      3A=20.300 us      C=20.300 us

REPLY DELAY 3A=3.05 us      ▶C=3.55 us
REPLY JITTER 3A=0.250 us    C=0.000 us
REPLY RATIO 3A=100%        C=100%
-81dBm REPLY RATIO 3A=0%    C=0%

ATCRBS ALL-CALL 3A=PASS     C=PASS

PULSE AMP VAR 3A=0.0 dB     C=0.0 dB

RUN TEST    PREV TEST    NEXT TEST    RETURN

```

Individual tests may be reviewed for failures which are identified by an arrow symbol.

MK12/S Transponder

Xpdr Auto-Test:

Every parameter the user commonly needs to view is displayed on one screen.

The auto-test performs all tests defined by FAR Part 43 Appendix F, including the proposed Eurocontrol additional tests.

The specific modes tested are determined by the selected config.

The Mode S tests are tailored automatically according to reported transponder level to avoid erroneous failures.

```

XPDR - CONFIG      BAT 2.5 Hr

1  GENERIC ATCRBS
2  ATCRBS CLASS A
3  ATCRBS CLASS B
4  GENERIC MODE S
5  MODE S CLASS A
6  MODE S CLASS B
7  MODE S CL B OPT FREQ
8  MODE S CL B OPT PWR
9  MK10A/MK12-M4
10 MK12/S-M4

INFO RETURN

```

```

XPDR - TEST LIST   BAT 2.5 Hr

1 3A/C DECDR/SLS      - PASS
2 1/2 DECDR/SLS      - PASS
3 3A/C F1/F2 SPACE/WIDTH - PASS
4 1/2 SPACE/WIDTH    - PASS
5 POWER/FREQ         - PASS
6 S ALL-CALL         - PASS
7 S REPLY TIMING     - PASS
8 S REPLY            - PASS
9 UF0                - PASS
10 UF4               - PASS
11 UF5               - PASS
12 UF11              - PASS

SELECT TEST    NEXT PAGE    RETURN

```

The test list is selected from the auto-test screen. This provides an easy means of selecting any of the individual tests that comprise the auto-test.

Tests on the 2nd screen (not shown) include:

- 13 UF16
- 14 UF20
- 15 UF21
- 16 UF24
- 17 ELEMENTARY SURVEILLANCE 1
- 18 ELEMENTARY SURVEILLANCE 2
- 19 ENHANCED SURVEILLANCE

User selects config required for test.

For ATCRBS and Mode S Transponders if the class of the transponder is unknown, the generic config may be selected which applies to the widest limits.

The test set will automatically determine the Mode S transponder level.

The selected config parameters may be displayed by pressing the INFO softkey.

Ten predetermined configs are provided to meet ATCRBS, Mode S, MK10, MK12, MK12/S transponder test needs.

```

XPDR-ELEMENT SURV2 PASS      BAT 2.5 Hr

BDS= 1,7 :0,5 :0,6 :0,7 :0,8 :0,9
      :0,A :2,0 :2,1 :4,0 :4,1 :4,2 :4,3
      :4,4 :4,5 :4,8 :5,0 :5,1 :5,2 :5,3
      :5,4 :5,5 :5,6 :5,F :6,0
BDS 1,8=0000000000000000
BDS 1,9=0000000000000000
BDS 1,A=0000000000000000
BDS 1,B=0000000000000000
BDS 1,C=0000000000000000
BDS=2,0 FLIGHT ID=UA661
BDS=3,0 ARA=11101010000000 RAC=1010
      RAT=0

RUN TEST    PREV TEST    NEXT TEST    RETURN

```

```

XPDR - ELEMENT SURV1 PASS BAT 2.5 Hr

BDS=1,0  SUBNETWORK VER =1
          ENH PROT IND   =LVL 2-4
          SPEC SERV CAP  =YES
          UELM CAPABILITY =16/1 s
          DELM CAPABILITY =16/500 ms
          AIRCRAFT ID CAP =YES
          SURV IDENT CAP  =YES
          COMM USE GICB REP=1
          DTE              =YES
          CONT FLAG       =YES
          SQUITTER CAP    =YES

RUN TEST  PREV TEST  NEXT TEST  RETURN

```

```

XPDR-S ALL-CALL PASS BAT 2.5 Hr

ITM REPLY
  DELAY      3A=128.08 us  C=128.07 us
  JITTER     3A=0.510 us  C=0.510 us
  ADDRESS    3A=2AC421    C=2AC421
  RATIO      3A=100%     C=100%
  -81dBm    3A=0%       C=0%

MODE S ALL-CALL= PASS
ADDRESS      = 2AC421
TAIL= N12345
COUNTRY= United States

RUN TEST  PREV TEST  NEXT TEST  RETURN

```

The Eurocontrol Elementary Surveillance DAP's (Downlink Aircraft Parameters) are displayed on two screens

```

XPDR-ENHANCED SURV PASS BAT 2.5 Hr

DF=20
BDS4,0  MCP/FCU SEL ALT =65520 ft
BDS5,0  ROLL ANGLE      = 40.1 deg
          TRUE TRACK ANGLE= 90.3 deg
          GROUND SPEED   = 512 kts
          TRACK ANGLE RATE= 4.00 deg/s
          TRUE AIR SPEED  = 512 kts
BDS6,0  MAGNETIC HEADING= 180.3 deg
          IND AIR SPEED   = 512 kts
          MACH NO        = 0.300
          INERT VERT VEL  =-1400 ft/min
          BARO ALT RATE  =-1400 ft/min

RUN TEST  PREV TEST  NEXT TEST  RETURN

```

```

TACAN T/R NORM BAT 2.5 Hr

CHAN: 17X          RF LVL: - 42.0 dBm
FREQ: 978 MHz     RATE: 1000 kts IN
                  RANGE: 100.00 nm

BRG:270.0 deg     IDENT:MORSE
% REPLY:100      SQTR :ON  ECHO:OFF

TX FREQ =1041.00 MHZ  ERP=250 WATTS
PRF=150 Hz
P1 WIDTH= 3.500 us  P2 WIDTH= 3.502 us
P1-P2 =12.0us(X)
UUT LVL = -78.2 dBm  SYNC=MRB

RUN TEST  PREV PARAM  NEXT PARAM  STOP RATE  IN/OUT

```

Eurocontrol Enhanced Surveillance DAP's are displayed on one screen.

TACAN

All the user needs are on one screen.

- RF level control for track sensitivity tests
- Supports all TACAN channels
- Full UUT measured parameters are displayed
- TACAN test modes; T/R Norm, T/R Range Only, T/R Inverse, A/A Beacon, A/A Range Only and A/A Inverse

```

XPDR - UFO PASS BAT 2.5 Hr

DF = 0
VS = 0 - IN AIR
CC = 0 - NOT SUPPORTED
SL = 0 - NO TCAS SENS LEVEL REPORTED
RI = 12 - AIRSPEED 301 TO 600 KNOTS

AC = 03A0(01640) 10700 FT
MODE C ALT COMPARE = PASS
AA = AC3421(53032041)
DF 11 ADDRESS COMPARE = PASS

RUN TEST  PREV TEST  NEXT TEST  RETURN

```

```

TCAS BAT 2.5 Hr

SCENARIO: 0-CUSTOM
TCAS TYPE:TCAS II %REPLY: 100
INTRUDER TYPE:MODE S
RANGE START: 10.00 nm STOP: 0.00 nm
RANGE RATE : 350 kts
ALT START: +1000 ft STOP: 0 ft
ALT RATE : 600 fpm CONVERGE :OFF
UUT ALT : 31200 ft ALT DETECT: ON
FREQ= 1030.00 MHz ERP= 57.0 dBm
RANGE= 21.00 nm IN ALT= +1000 ft ↓
TCAS STATUS= TRACKING
STATUS= NON-THREAT ENCOUNTER= 0:00

RUN TEST  PREV PARAM  NEXT PARAM  MON  STORE/RECALL

```

No more HEX data field interpretation!

All Mode S Format tests display parameter in engineering units.

```

XPDR-UF11 PASS BAT 2.5 Hr

DF=11
CA=0-LEVEL 2 CA MODE
PI =02F08D
AA=AC3421(53032041)
II LOCKOUT TIMER=18S
II MATCH=PASS
SI LOCKOUT TIMER=18S
SI MATCH=PASS

RUN TEST  PREV TEST  NEXT TEST  RETURN

```

TCAS

TCAS types...

TCAS 1 MODE C

TCAS 2 ATCRBS

TCAS 2 MODE S

E-TCAS

The Auto-Altitude feature interrogates Mode S XPDR of aircraft under test to obtain current altitude.

Select pre-stored named scenarios directly from the auto-test screen.

Comprehensive II / SI code and lockout timer test

```

TCAS                                BAT 2.5 Hr
SCENARIO: 0-CUSTOM
TCAS TYPE:E-TCAS                    %REPLY: 100
INTRUDER TYPE:MODE S                CODE:4567
RANGE START: 10.00 nm               STOP: 0.00 nm
RANGE RATE : 350 kts
ALT START: +1000 ft                 STOP: 0 ft
ALT RATE : 600 fpm                  CONVERGE :OFF
UUT ALT : 31200 ft                  ALT DETECT: ON
FREQ= 1030.00 MHz                   ERP= 57.0 dBm
RANGE= 21.00 nm IN                  ALT= +1000 ft ↓
TCAS STATUS= TRACKING
STATUS= NON-THREAT                   ENCOUNTER= 0:00

```

```

ADS-B MON BDS 0,5                   AVAIL   BAT 2.5 Hr
BDS=0,5 AIRBORNE POS                TYPE=14
DF 17 AA=3AC421 (16542041)          COUNT=1000
ME=0000000000000000                PERIOD=DEFAULT
LAT= 37 39 00 N                     LONG= 97 25 48 W
POS=GLOBAL SAF=1                    T=N/UTC
SURVEILLANCE STATUS                 = NO INFO
BARO PRES ALT=131025 ft

```

ADS-B MON:

The BDS DATA screen displays full content of selected BDS format being received via DF17, DF18 or DF19 extended squitters.

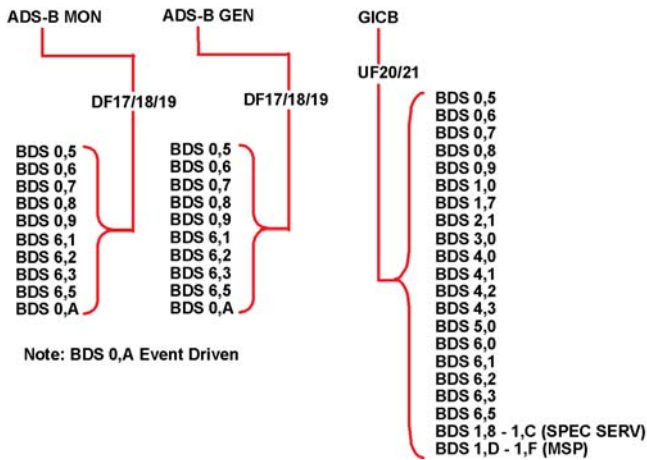

```

ADS-B GEN DF17                       BAT 2.5 Hr
1 0,5 AIRBORNE POS                   - DISABLED
2 0,6 SURFACE POS                    - ENABLED
3 0,8 IDENT & CAT                     - ENABLED
4 0,9 AIRBORNE VEL                   - ENABLED
5 0,A ADS-B TEST MSG                 - ENABLED
6 6,1 A/C STATUS                     - ENABLED
7 6,2 TARG STATE                     - ENABLED
8 6,3 A/C OP STATUS                  - ENABLED
9 6,5 A/C OP STATUS                  - ENABLED

```

ADS-B GEN:

The BDS LIST shows BDS formats supported. The BDS SELECT key selects individual BDS numbers. The BDS ENABLE/DISABLE key enables or disables the selected BDS number for squittering via DF17 or DF18 extended squitter. The BDS DATA key displays the BDS DATA screen for the selected BDS number.

ADS-B and GICB

ADS-B MON: Used to monitor DF17 extended squitter from transponders and DF18 extended squitter from 1090 MHz ADS-B emitters.

ADS-B GEN: Used to generate DF17/DF18 extended squitter, simulating transponders and 1090 MHz ADS-B emitters.

GICB: Used to monitor DAP's (all fields).

```

ADS-B MON DF17                       BAT 2.5 Hr
1 0,5 AIRBORNE POS                   - AVAIL
2 0,6 SURFACE POS                    - NOT CAP
3 0,8 IDENT & CAT                     - AVAIL
4 0,9 AIRBORNE VEL                   - AVAIL
5 0,A ADS-B TEST MSG                 - AVAIL
5 6,1 A/C STATUS                     - AVAIL
6 6,2 TARG STATE                     - AVAIL
7 6,3 A/C OP STATUS                  - NO SQTR
8 6,5 A/C OP STATUS                  - NO SQTR

```

```

ADS-B GEN BDS 0,5                   BAT 2.5 Hr
BDS=0,5 AIRBORNE POS                TYPE: 9
DF 19 AA:3AC421 (16542041)          COUNT=1000
ME=490844AE8319EA                  PERIOD: 1.00 s
LAT: 37 39 00 N                     LONG: 97 25 48 W
POS:                                SAF:1   T:N/UTC
SURVEILLANCE STATUS : NO INFO
BARO PRES ALT:126700 ft
GNSS ALT : N/A

```

ADS-B GEN:

BDS DATA screens display full content of the selected BDS format in RTCA/ICAO engineering units.

The NEXT PARAM and PREV PARAM keys select data fields for editing via the data slew keys.

ADS-B MON:

The ADS-B MON LIST shows BDS formats supported.

The BDS status is annunciated to indicate if the squitter has been captured, not available or not seen.

The BDS DATA key displays the BDS DATA screen for the selected BDS number.

```

GICB DF20          BAT 2.5 Hr
1 0,5 AIRBORNE POS - AVAIL
2 0,6 SURFACE POS  - NOT CAP
3 0,7 SQTR STATUS  - AVAIL
4 0,8 IDENT & CAT   - AVAIL
5 0,9 AIRBORNE VEL - AVAIL
6 1,0 DATA LNK CAP - AVAIL
7 1,7 COM GICB CAP - AVAIL
8 1,8 SPEC SERV CAP #1 - AVAIL
9 1,9 SPEC SERV CAP #2 - AVAIL
10 1,A SPEC SERV CAP #3 - AVAIL
11 1,B SPEC SERV CAP #4 - AVAIL
12 1,C SPEC SERV CAP #5 - AVAIL

RUN TEST  BDS DATA  RETURN

```

GICB:

The BDS LIST shows BDS formats supported.

The BDS DATA key displays the BDS DATA screen for the selected BDS number.

```

GICB BDS 3,0      AVAIL  BAT 2.5 Hr
BDS=3,0 ACAS ARA
DF20 AA=3AC421 (16542041)
MB=00000000000000
TIDB= 70 deg
TIDA= 32000 ft      TIDR= 1.00 nm
ARA=11101010000000 TID=3A4518
RAC=1010  RAT=1  MTE=3
THREAT ADDRESS=N/A
TTI=2-ALT/RANGE/BEARING DATA

RUN TEST  PREV TEST  PREV TEST  RETURN

```

GICB:

BDS DATA screens display full content of the selected BDS format being received via GICB DF20 or DF21 in RTCA/ICAO engineering units.

```

TIS          BAT 2.5 Hr
TARGETS:5      UUT HDG:180 deg
                1      2      3      4      5
BRG(deg) : 120  90  234  182  23
RNG(nm)  : 6.00  4.00  3.00  2.00  1.00
ALT(ft)   : 3500  2000  1000  500  0
ALT RATE:CLIMB LEVEL LEVEL CLIMB LEVEL
HDG(deg)  : 234  178  56  22  0
TRAFFIC : PROX PROX PROX PROX TRFC

ADDR=3AC421 (16542041) N12345
TSCR= 5  TSDR= 1  ALT =126700 ft
TIS STATUS=CONNECTING INFO=0000

RUN TEST  PREV PARAM  NEXT PARAM

```

TIS

Up to 5 static intruders may be simulated relative to the A/C (UUT).

General

Radiated Testing:

The IFR 6015 is supplied with a lightweight, fully sealed, directional antenna that may be test set mounted, hand held or tripod mounted.

Direct Connect Testing:

The IFR 6015 may be directly connected to the UUT via a supplied RF coax cable via the RF I/O port.



Transit Case:

The IFR 6015 is supplied in a rugged plastic transit case which provides stowage for the test set, directional antenna, RF coax cable, antenna shield, breakout box, and power supply/charger.



SPECIFICATION

Notes

- ▲ - IFF System Information in Public Domain
- ⌘ - TACAN System Information in Public Domain (Ref. MIL STD 291C)

TACAN/DME MODE SPECIFICATIONS

SIGNAL GENERATOR

A 5-minute warm-up period is required for all specifications.

OUTPUT FREQUENCY

REPLY FREQUENCY

Range

962 to 1213 MHz

Accuracy

± 10 kHz

⌘ Variable Channel Selection 1 to 126 (X & Y)

Preset Channel Selection

⌘ Preset 1 (DoD)

T/R Mode 17X, 18X

A/A Mode 17X, 17Y

Inverse A/A Mode 80X, 80Y

⌘ Preset 2 (AN/ASM-663)

5X, 5Y, 47X, 47Y, 89X, 89Y

Preset 3 (AN/ARM-184) No Preset

Preset 4 (2650/2655)

18X, 18Y, 47X, 47Y, 100X, 100Y, 123X, 123Y

OUTPUT LEVEL

ANTENNA PORT

Range

-67 to -5 dBm at antenna port (T/R Norm, T/R Inv, A/A Beacon, A/A Inv)

-67 to -2 dBm at antenna port (T/R Rng Only, A/A Rng Only)

Resolution

0.5 dB

Accuracy

± 2 dB

Distance to UUT antenna

6 to 250 ft with supplied antenna

RF I/O PORT

Range

-115 to -50 dBm at antenna port (T/R Norm, T/R Inv, A/A Beacon, A/A Inv)

-115 to -47 dBm at antenna port (T/R Rng Only, A/A Rng Only)

Resolution

0.5 dB

Accuracy

-95 dBm to -50 dBm ± 1 dB

Accuracy

-115 dBm to <-95 dBm ± 2 dB

REPLY PULSE SPACING

P1 to P2

12 μs ± 0.1 μs (T/R X Channel) @ 50% peak

P1 to P2

30 μs ± 0.1 μs (T/R Y Channel) @ 50% peak

REPLY PULSE WIDTH

P1/P2

3.5 μs ± 0.5 μs

ECHO REPLY

Control

On/Off

Position

30 nmi ± 1 nmi

Amplitude

-11 dB ± 1 dB relative to reply level

REPLY PULSE RISE AND FALL TIMES

ALL PULSES

Rise Time

2.5 μs ± 0.25 μs (10% to 90%)

Fall Time

2.5 μs ± 0.25 μs (90% to 10%)

REPLY DELAY

T/R X CHANNEL

Fixed Reply Delay

50 μs ± 100 ns

T/R Y CHANNEL

Fixed Reply Delay

56 μs ± 100 ns

⌘ A/A X CHANNEL

Fixed Reply Delay

62 μs ± 100 ns

⌘ A/A Y CHANNEL

Fixed Reply Delay

74 μs ± 100 ns

VARIABLE RANGE DELAY

X AND Y CHANNEL

Range

0 to 450.00 nmi

Resolution

0.01 nmi

Accuracy

± 0.01 nmi

PRESET RANGE DELAY

X AND Y CHANNEL

Preset 1 (DoD) Range

0, 3, 10, 30, 100, 200, 300, 400 nmi

Preset 2 (AN/ASM-663) Range

0, 10, 150, 297 nmi

Preset 3 (AN/ARM-184) Range

0, 50, 100, 150, 200, 250, 300, 350, 400 nmi

Preset 4 (2650/2655) Range

0, 5, 125, 283 nmi

Resolution

0.01 nmi

Accuracy

± 0.01 nmi

VARIABLE RANGE RATE

X AND Y CHANNEL

Rate

0 to 6500 kts

Resolution

1 kts

Accuracy

$\pm 0.01\%$ typical, tested to $\pm 0.5\%$

PRESET RANGE RATE

X AND Y CHANNEL

Preset 1 (DoD) Rate

0, 250 kts (1000 kts in A/A modes)

Preset 2 (AN/ASM-663) Rate

No Rate

Preset 3 (AN/ARM-184) Rate

0, 2400 kts

Preset 4 (2650/2655) Rate

No Rate

Resolution

1 kts

Accuracy

$\pm 0.01\%$ typical, tested to $\pm 0.5\%$

SQUITTER

% PRF

T/R(X) & T/R(Y) NORM, INVERSE, RNG ONLY

2700 Hz

A/A RNG ONLY, BEACON, INVERSE

1350 Hz

Accuracy

$\pm 2\%$

Distribution

Per MIL STD 291C and ARINC 568

REPLY EFFICIENCY

Range

0 to 100%

Resolution

1% increments

Accuracy

$\pm 0.5\%$

% IDENT TONE PULSE PAIR

T/R(X) & T/R(Y) Modes Selection

Selectable four letter code or tone

Frequency

1350 Hz

Accuracy

± 2 Hz

Equalizer pulse pair

Spacing from Ident pair $100 \mu\text{s} \pm 10 \mu\text{s}$

% IDENT TONE SINGLE PULSE

A/A(X) & A/A(Y) Modes Selection

Selectable four letter code or tone

Frequency

1350 Hz

Accuracy

± 2 Hz

INVERSE MODE

A/A(X), A/A(Y), T/R(X), T/R(Y)

Active Low North Reference Trigger Sync Output

% A/A MODE INTERROGATION

P1 to P2

$12 \mu\text{s} \pm 0.1 \mu\text{s}$ (A/A X Channel) @ 50% peak

P1 to P2

$24 \mu\text{s} \pm 0.1 \mu\text{s}$ (A/A Y Channel) @ 50% peak

Interrogation Rate

150 PPS, ± 5 Hz

% 15/135 HZ BEARING SIGNAL

Modulation Levels

15 Hz 21% $\pm 2.5\%$

135 Hz 21% $\pm 2.5\%$

Frequency

15/135 Hz $< \pm 0.2\%$

Phase Accuracy

$< \pm 0.3^\circ$

Distortion

$< 2.5\%$

% BEARING

Variable

0 to 359.5° in 0.5° increments

Accuracy

$\pm 0.1^\circ$

PRESET

Preset 1 (DoD) Range

0°, 45°, 90°, 135°, 180°, 225°, 270°, 315°

Preset 2 (AN/ASM-663) Range

0°, 45°, 180°, 225°

Preset 3 (AN/ARM-184) Range

0°, 90°, 180°, 337.5°

Preset 4 (2650/2655) Range

90°, 230°, 320°

INTERROGATION PULSE DECODING

Must Reply nominal code pair spacing

$< \pm 0.5 \mu\text{s}$

Must Not Reply nominal code pair spacing

$> \pm 1.0 \mu\text{s}$

% MRB T/R(X)

Group

12 pairs of pulses

Pulse Spacing

$12 \mu\text{s} \pm 0.1 \mu\text{s}$

Pulse Pair Spacing

$30 \mu\text{s} \pm 0.1 \mu\text{s}$

% MRB T/R(Y)

Group

13 single pulses

Pulse Spacing

30 $\mu\text{s} \pm 0.1 \mu\text{s}$

% MRB A/A BEACON (X & Y)

Group

10 single pulses

Pulse Pair Spacing

30 $\mu\text{s} \pm 0.1 \mu\text{s}$

% ARB T/R(X)

Group

6 pairs of pulses

Pulse Spacing

12 $\mu\text{s} \pm 0.1 \mu\text{s}$

Pulse Pair Spacing

24 $\mu\text{s} \pm 0.1 \mu\text{s}$

% ARB T/R(Y)

Group

13 single pulses

Pulse Spacing

15 $\mu\text{s} \pm 0.1 \mu\text{s}$

UUT MEASUREMENTS

ERP

Range

+47 to +64 dBm

Resolution

0.1 dB

Accuracy

± 2 dB

DIRECT CONNECTION PEAK PULSE POWER

Range

+47 to +64 dBm

Resolution

0.1 dB

Accuracy

± 1 dB

FREQUENCY

Range

1025.00 to 1150.00 MHz

Resolution

10 kHz

Accuracy

± 20 kHz

INTERROGATION PULSE WIDTH

P1 AND P2 PULSE WIDTHS

Range

2.00 to 5.00 μs

Resolution

1 ns

Accuracy

± 50 ns

% INTERROGATION PULSE SPACING

P1 to P2 Spacing

10 to 14 μs (T/R X and A/A X Channel)

P1 to P2 Spacing

22 to 26 μs (A/A Y Channel)

P1 to P2 Spacing

34 to 38 μs (T/R Y Channel)

Resolution

10 ns

Accuracy

± 20 ns

INTERROGATION PRF

Range

1 to 300 Hz

Resolution

1 Hz

Accuracy

± 2 Hz

% A/A REPLY DELAY

A/A(X)

62 μs (-2 +4 μs accept)

A/A(Y)

74 μs (-2 +4 μs accept)

Resolution

10 ns

Accuracy

± 100 ns

TRANSPONDER MODE SPECIFICATIONS

SIGNAL GENERATOR

RF OUTPUT FREQUENCY

Interrogation Frequency

1030 MHz

Accuracy

± 10 kHz

RF OUTPUT LEVEL

ANTENNA PORT

MTL + 6 dB typical, automatically controlled for a MTL range of -83 to -68 dBm

Range

-67 to -2 dBm at antenna port

Resolution

0.5 dB

Accuracy

± 2 dB

Distance to UUT antenna

6 to 200 ft with supplied antenna

RF I/O PORT

MTL + 6 dB typical, automatically controlled

Range

-115 to -47 dBm

Resolution

0.5 dB

Accuracy

-95 to -47 dBm, ± 1 dB

Accuracy

-115 to <-95 dBm, ± 2 dB

ATCRBS/SIF/MODE S INTERROGATION PULSE SPACING

▲ MODE 1

P1 to P2

2.00 μ s ± 25 ns

P1 to P3

3.00 μ s ± 25 ns

▲ MODE 2

P1 to P2

2.00 μ s ± 25 ns

P1 to P3

5.00 μ s ± 25 ns

MODE 3A

P1 to P2

2.00 μ s ± 25 ns

P1 to P3

8.00 μ s ± 25 ns

MODE C

P1 to P2

2.00 μ s ± 25 ns

P1 to P3

21.00 μ s ± 25 ns

MODE S

P1 to P2

2.00 μ s ± 25 ns

P1 to P6

3.50 μ s ± 25 ns

P1 to SPR

4.75 μ s ± 25 ns

P5 to SPR

0.40 μ s ± 50 ns

INTERMODE INTERROGATION PULSE SPACING

MODE A

P1 to P3

8.00 μ s ± 25 ns

P1 to P4

10.00 μ s ± 25 ns

MODE C

P1 to P3

21.00 μ s ± 25 ns

P1 to P4

23.00 μ s ± 25 ns

INTERROGATION PULSE WIDTHS

MODE A,C,S,INTERMODE

P1,P2,P3

0.80 μ s ± 50 ns

MODE S

P6 (Short DPSK Block)

16.25 μ s ± 50 ns

P6 (Long DPSK Block)

30.25 μ s ± 50 ns

P5

0.80 μ s ± 50 ns

INTERMODE

P4 (Short)

0.80 μ s ± 50 ns

P4 (Long)

1.60 μ s ± 50 ns

INTERROGATION PULSE RISE AND FALL TIMES

ALL MODES

Rise Time

50 to 100 ns

Fall Time

50 to 200 ns

PHASE MODULATION

ALL MODES

Transition Time

≤ 80 ns

Phase Shift

180° ± 10 °

SLS LEVELS

ATCRBS/SIF

SLS Level (P2)

-9 dB, -1 to +0 dB relative to P1 level

0 dB, -0 to +1 dB relative to P1 level

Off

MODE S

SLS Level (P5)

-12 dB, -1 to +0 dB relative to P6 level

+3 dB, -0 to +1 dB relative to P6 level

Off

Note: SLS level is automatically controlled in the SLS LEVEL test.

INTERROGATION TEST SIGNALS

MODE S

PRF

50 Hz ± 5 Hz

ATCRBS/SIF

PRF

235 Hz ± 5 Hz

UUT MEASUREMENTS

ERP (@ 1090 MHZ)

Range

+ 45.5 to + 59 dBm (35.5 to 800 watts)

Resolution

0.1 dB

Accuracy

± 2 dB

Direct Connection Peak Pulse Power (@1090 MHz)

Range

+ 46.5 to + 59 dBm (45 to 800 watts)

Resolution

0.1 dB

Accuracy

± 1 dB

TRANSMITTER FREQUENCY

Range

1087.000 to 1093.000 MHz

Resolution

10 kHz

Accuracy

± 50 kHz

RECEIVER SENSITIVITY, RADIATED MTL

Range

-67 to -79 dBm into 0 dBi antenna

Resolution

0.1 dB

Accuracy

± 2 dB, typical

RECEIVER SENSITIVITY, DIRECT CONNECTION MTL

Range

-67 to -79 dBm

Resolution

0.1 dB

Accuracy

± 2 dB

REPLY DELAY

ATCRBS/SIF

Range

1.80 to 7.00 μs

Resolution

10 ns

Accuracy

± 50 ns

REPLY DELAY, MODE S AND ATCRBS MODE S ALL-CALL

Range

125.00 to 131.00 μs

Resolution

10 ns

Accuracy

± 50 ns

REPLY DELAY JITTER

ATCRBS/SIF

Range

0.00 to 2.30 μs

Resolution

1 ns

Accuracy

± 20 ns

MODE S AND ATCRBS MODE S ALL-CALL

Range

0.00 to 6.00 μs

Resolution

1 ns

Accuracy

± 20 ns

PULSE SPACING

F1 TO F2

Range

19.70 to 21.60 μs

Resolution

1 ns

Accuracy

± 20 ns

MODE S PREAMBLE

Range, P1 to P2

0.8 to 1.2 μs

Range, P1 to P3

3.3 to 3.7 μs

Range, P1 to P4

4.3 to 4.7 μs

Resolution

1 ns

Accuracy

± 20 ns

PULSE DECODER

Modes 1,2,3/A

4096 code & binary equivalent displayed, including X pulse.
Ident & Emergency Replies displayed.

Mode C

Altitude

PULSE WIDTHS

F1 AND F2

Range

0.25 to 0.75 μs

Resolution

1 ns

Accuracy

± 20 ns

MODE S PREAMBLE

Range

0.25 to 0.75 μs

Resolution

1 ns

Accuracy

± 20 ns

PULSE AMPLITUDE VARIATION

Range, Mode S (Relative to P1)

+3 to -3 dB

Range, ATCRBS/SIF (Relative to F1)

+3 to -3 dB

Resolution

0.1 dB (0.01 dB via RCI)

Accuracy

± 0.5 dB

DF 11 SQUITTER PERIOD

Range

0.10 to 4.88 sec

Resolution

10 ms

Accuracy

± 10 ms

DIVERSITY ISOLATION

Range

0 to >20 dB (Depending on Test Distance)

Test Distance

1.83m (6ft) to 28.96m (95ft)

Resolution

0.1 dB

Accuracy

± 3 dB

TCAS/E-TCAS MODE SPECIFICATIONS

SIGNAL GENERATOR

OUTPUT FREQUENCY

REPLY FREQUENCY

1090 MHz

Accuracy

± 10 kHz

OUTPUT LEVEL (SIMULATED ERP)

ANTENNA PORT Note 1**Radiated power at 0 dBi UUT antenna**

-68 dBm typical @ 10 Nmi Range, automatically controlled

Range

-67 to -2 dBm at Antenna port

Resolution

0.5 dB

Accuracy

± 2 dB

Distance to UUT antenna

6 to 300 ft with supplied antenna

RF I/O PORT**Automatic mode**

-68 dBm @ 10 Nmi Range, automatically controlled

Manual mode Range

-115 to -47 dBm

Resolution

0.5 dB

Accuracy

-95 to -47 dBm, ± 1 dB

Accuracy

-115 to <-95 dBm, ± 2 dB

REPLY PULSE SPACING

MODE C**F1 to F2**

20.30 μs ± 25 ns

F1 to C1

1.45 μs ± 25 ns

F1 to A1

2.90 μs ± 25 ns

F1 to C2

4.35 μs ± 25 ns

F1 to A2

5.80 μs ± 25 ns

F1 to C4

7.25 μs ± 25 ns

F1 to A4

8.70 μs ± 25 ns

F1 to B1

11.60 μs ± 25 ns

F1 to D1

13.05 μs ± 25 ns

F1 to B2

14.50 μs ± 25 ns

F1 to D2

15.95 μs ± 25 ns

F1 to B4

17.40 μs ± 25 ns

F1 to D4

18.85 μs ± 25 ns

MODE S**P1 to P2**

1.00 μs ± 25 ns

P1 to P3

3.50 μs ± 25 ns

P1 to P4

4.50 μs ± 25 ns

P1 to D1

8.00 μs ± 25 ns

D1 to Dn (n=2 to 112)

1.00 μs times (n-1) ± 25 ns

REPLY PULSE WIDTHS

MODE C**All Pulses**

0.45 μs ± 50 ns

MODE S**P1 through P4**

0.50 μs ± 50 ns

D1 through D112

0.50 μs ± 50 ns, 1 μs chip width

Reply Modes

TCAS I / II Mode C (with altitude reporting)

TCAS II Mode S formats 0, 11, 16

E-TCAS Modes formats 0, 4, 5, 11, 16, 20, 21

REPLY PULSE AMPLITUDES

ATCRBS

± 1 dB relative to F1

Mode S

± 1 dB relative to P1

REPLY PULSE RISE AND FALL TIMES

ALL MODES**Rise Time**

50 to 100 ns

Fall Time

50 to 200 ns

PERCENT REPLY

Range

0 to 100%

Resolution

10%

Accuracy

± 1%

RANGE RATE

Range

-1200 to +1200 kts

Resolution

10 kts

Accuracy

10%

ALTITUDE RANGE

Range

-1000 to 126,000 ft

Resolution, Mode C

100 ft

Resolution, Mode S

25 ft

ALTITUDE RATE

Range

-10,000 to +10,000 fpm

Resolution

100 fpm

Accuracy

10%

SQUITTER

Control

On/Off

Rate

0.8 to 1.2 seconds, randomly distributed

RECEIVER

PULSE SPACING

ATCRBS (Mode C All Call)

S1 to P1 2.0 us

Accepts ≤ ±200 ns

Rejects ≥ ±1.0 us

P1 to P3 21.0 us

Accepts ≤ ±200 ns

Rejects (<10% Replies) ≥ ±1.0 us

P1 to P4 23.0 us

Accepts ≤ ±200 ns

Rejects (<10% Replies) ≥ ±1.0 us

Mode S

P1 to P2 2.0 us

Accepts ≤ ±200 ns

Rejects (<10% Replies) ≥ ±1.0 us

P1 to SPR 4.75 us

Accepts ≤ ±200 ns

Rejects (<10% Replies) ≥ ±1.5 us

SUPPRESSION

ATCRBS (P2 or S1)

>0.5dB above level of P1 <10% Replies

UUT MEASUREMENTS

ERP (@1030MHZ)

ATCRBS

Range

+43 to +58 dBm (20 to 631 watts)

Resolution

0.1 dB

Accuracy

± 2 dB

MODE S

Range

+43 to +58 dBm (20 to 631 watts)

Resolution

0.1 dB

Accuracy

± 2 dB

DIRECT CONNECTION PEAK PULSE POWER (@1030MHZ)

ATCRBS

Range

+43 to +58 dBm (20 to 631 watts)

Resolution

0.1 dB

Accuracy

± 1 dB

MODE S

Range

+43 to +58 dBm (20 to 631 watts)

Resolution

0.1 dB

Accuracy

± 1 dB

FREQUENCY

Range

1029.900 to 1030.100 MHz

Resolution

1 kHz

Accuracy

± 10 kHz

TCAS BROADCAST INTERVAL

Range

1.0 to 12.0 sec

Resolution

0.1 sec

Accuracy

± 0.2 sec

MISCELLANEOUS INPUT/OUTPUTS

RF I/O

Type

Input/Output

Impedance

50 Ω typical

Maximum Input Level

4 kW peak

10 W average

VSWR

< 1.3:1

ANTENNA**Type**

Input/Output

Impedance

50 Ω typical

Maximum Input Level

10 kW peak

1/2 W average

VIDEO**Type**

Output

Impedance

50 Ω typical

Generate Video Level

1.1 \pm 0.4V peak to peak into 50 Ω

Receive Video Level

Proportional to IF level

Baseline

\pm 0.5V referenced to ground

TEST ANTENNA

VSWR

< 1.5:1

Gain

6 dB, Typical

TIME BASE (TCXO)

Temperature Stability

\pm 1 ppm

Aging

\pm 1 ppm per year

Accuracy

\pm 1 ppm

Test Limit

\pm 0.3 ppm

BATTERY

Type

Li Ion

Duration

> 4 hrs continuous operation

> 6 hrs, Typical

INPUT POWER (TEST SET)

Input Range

11 VDC to 32 VDC

Power Consumption

55 W Maximum

16 W Nominal at 18 VDC with charged battery

Fuse Requirements

5 A, 32 VDC, Type F

INPUT POWER (SUPPLIED EXTERNAL AC TO DC CONVERTER)

Input Range

100 to 250 VAC, 1.5 A Max, 47-63 Hz

Mains Supply Voltage Fluctuations

\leq 10% of the nominal voltage

Transient Overvoltages

According to Installation Category II

ENVIRONMENTAL (TEST SET)

Use

Pollution Degree 2

Altitude

\leq 4800 meters

Operating Temperature

^{NOTE 3} -20°C to 55°C

Storage Temperature

^{NOTE 4} -30°C to 71°C

Relative Humidity

95% \pm 5% from 5° to 30°C

75% \pm 5% from 30° to 40°C

45% \pm 5% from 40° to 55°C

ENVIRONMENTAL (SUPPLIED EXTERNAL AC TO DC CONVERTER)

Use

Indoors

Altitude

\leq 10,000 meters

Operating Temperature

0° to 40°C

Storage Temperature

-20°C to 71°C

PHYSICAL CHARACTERISTICS

DIMENSIONS**Height**

11.2 inches (28.5 cm)

Width

9.1 inches (23.1 cm)

Depth

2.7 inches (6.9 cm)

Weight (Test set only)

< 8 lbs. (3.6 kg)

SUPPLEMENTAL INFORMATION

Test Set Certifications

Altitude, operating	MIL-PRF-28800F	Class 2
Altitude, not operating	MIL-PRF-28800F	Class 2
Bench Handling	MIL-PRF-28800F	Class 2
Blowing Dust	MIL-STD-810F	Method 510.4, Procedure I
Drip-proof	MIL-PRF-28800F	Class 2
Explosive Atmosphere	MIL-STD-810F	Method 511.4, Procedure 1
Relative Humidity	MIL-PRF-28800F	Class 2
Shock, Functional	MIL-PRF-28800F	Class 2
Vibration Limits	MIL-PRF-28800F	Class 2
Temp, operating ^{NOTE 5}	MIL-PRF-28800F	Class 2
Temp, not operating ^{NOTE 6}	MIL-PRF-28800F	Class 2
Transit Drop	MIL-PRF-28800F	Class 2
Safety Compliance	UL-61010B-1	
	EN 61010-1	
	CSA 22.2 No 61010-1	
EMC	EN 61326	

EXTERNAL AC-DC CONVERTER CERTIFICATIONS

Safety Compliance	UL 1950 DS
	CSA 22.2 No. 234
	VDE EN 60 950
EMI/RFI Compliance	FCC Docket 20780 Curve "B"
EMC	EN 61326

TRANSIT CASE CERTIFICATIONS

Drop Test	FED-STD-101C	Method 5007.1 Paragraph 6.3, Procedure A, Level A
Falling Dart Impact	ATA 300	Category I
Vibration, Loose Cargo	FED-STD-101C	Method 5019
Vibration, Sweep	ATA 300	Category I
Simulated Rainfall	MIL-STD-810F	Method 506.4 Procedure II of 4.1.2
	FED-STD-101C	Method 5009.1 Sec 6.7.1
Immersion	MIL-STD-810F	Method 512.4

Notes

- ^{NOTE 1} Simulates a 50.5 dBm XPDR ERP at 10 nMi range.
- ^{NOTE 2} Level automatically controlled based on actual distance to UUT antenna.
- ^{NOTE 3} Battery charging temperature range: 5°C to 40°C (controlled by internal charger).
- ^{NOTE 4} Li Ion Battery must be removed below -20°C and above 60°C.
- ^{NOTE 5} Temperature range extended to -20°C to 55°C.
- ^{NOTE 6} Temperature range reduced to -30°C to 71°C.

VERSIONS AND ACCESSORIES

When ordering please quote the full ordering number information.

Ordering Numbers

6015-110

Versions

IFR 6015 Mode 1,2,3A/C/S Transponder, TACAN/DME, TCAS I,II,E-TCAS, TIS Ramp

Test Set, with US Mains Leads

6015-220

IFR 6015 Mode 1,2,3A/C/S Transponder, TACAN/DME, TCAS I,II,E-TCAS, TIS Ramp Test Set, with European Mains Leads

6015OPT3

ADS-B

Extended Standard Warranties with Calibration for 6015

W6015/203C Extended standard warranty 36 months with scheduled calibration

W6015/205C Extended standard warranty 60 months with scheduled calibration

Accessories for 6015

AC0820	Desk Top Stand
AC0826	Tripod
AC0825CD	IFR 6015 Operation Manual - CD
AC24006	Tripod, Dolly, Stand

EXPORT CONTROL:

This product is controlled for export under the International Traffic in Arms Regulations (ITAR). A license from the U.S. Department of State is required prior to the export of this product from the United States.

EXPORT WARNING:

Aeroflex's military products are controlled for export under the International Traffic in Arms Regulations (ITAR) and may not be sold or proposed or offered for sale to certain countries including: Belarus, Burma, China, Cuba, Haiti, Iran, Liberia, Libya, North Korea, Somalia, Syria, Sudan, and Vietnam. See ITAR 126.1 for complete information.

For the very latest specifications visit www.aeroflex.com

FINLAND

Tel: [+358] (9) 2709 5541
Fax: [+358] (9) 804 2441

FRANCE

Tel: [+33] 1 60 79 96 00
Fax: [+33] 1 60 77 69 22

GERMANY

Tel: [+49] 8131 2926-0
Fax: [+49] 8131 2926-130

INDIA

Tel: [+91] 80 5115 4501
Fax: [+91] 80 5115 4502

KOREA

Tel: [+82] (2) 3424 2719
Fax: [+82] (2) 3424 8620

SCANDINAVIA

Tel: [+45] 9614 0045
Fax: [+45] 9614 0047

SPAIN

Tel: [+34] (91) 640 11 34
Fax: [+34] (91) 640 06 40

UK Cambridge

Tel: [+44] (0) 1763 262277
Fax: [+44] (0) 1763 285353

UK Stevenage

Tel: [+44] (0) 1438 742200
Fax: [+44] (0) 1438 727601
Freephone: 0800 282388

USA Wichita

Tel: [+1] (316) 522 4981
Fax: [+1] (316) 522 1360
Toll Free: 800 835 2352

USA New Century

Tel: [+1] (913) 764 2452
Fax: [+1] (913) 782 5104



As we are always seeking to improve our products, the information in this document gives only a general indication of the product capacity, performance and suitability, none of which shall form part of any contract. We reserve the right to make design changes without notice. All trademarks are acknowledged. Parent company Aeroflex, Inc. ©Aeroflex 2006.

www.aeroflex.com
info-test@eroflex.com



Our passion for performance is defined by three attributes represented by these three icons: solution-minded, performance-driven and customer-focused.